

# LeakMatic

## Data Sheet

## Full automatic non-destructive leak detector

- Leak detection of ALL your packages is ensured



### Features

- Fast detection of micro leaks
- In-line leak detection
- Non-destructive leak test
- Easy to set up and operate
- 16 set-up programmes for full data logging and statistics
- Complete self-diagnostics
- 100% leak test of the packaging line
- Touch screen operated control unit with an icon based user interface
- Computer interface for exporting logged data
- Sturdy industrial design
- Test of flexible and non-flexible packages
- No calibration of the sensor needed
- Tests 4-5 shipping crates a minute
- **NEW!** "LeakStat" software, all measurements can be logged and processed for statistical use

### Introduction to the LeakMatic

The LeakMatic is a non-destructive fully automatic in-line leak detector, using CO<sub>2</sub> as trace gas. With the LeakMatic it is possible to leak test all your packages before they are leaving the packaging line. The LeakMatic detects micro leaks in flexible and non-flexible packages containing a wide range of products like pasta, bread, cheese, meat, milk powder cans etc., directly from the packaging line.

The system has been designed to test several cartons or boxes containing numerous packages at once. The basic principle of the LeakMatic is that the package is placed inside a test chamber whereafter a user-defined vacuum is created. The vacuum will establish a pressure difference between the inside of the package and the test chamber causing CO<sub>2</sub> from the package to enter the test chamber through even the smallest leak. A highly sensitive sensor measures all changes in the CO<sub>2</sub> content and will detect even micro leaks.

### Fast and sensitive

Using our highly sensitive CO<sub>2</sub> sensor, the LeakMatic can test packages with a content as little as 10% CO<sub>2</sub>. The LeakMatic is designed to work in-line and can perform 4-5 full automatic leak detection tests per minute. This allows a 100% leak test of the entire production and minimize the risk of delivering leaking packages, which in worst case can damage your company image.

### Easy operation and self-diagnostic

On the front panel the LeakMatic has a graphical LCD touch screen from where the system can be set up and operated. The touch screen has back light and uses unmistakable icons to guide you through the various functions, furthermore the user interface comes in multiple languages versions, which makes the LeakMatic very easy to set up and to operate. The user interface has two user levels, the supervisor level can be password protected, allowing only authorised personnel to change the configuration of the LeakMatic.

The LeakMatic has a self-diagnostic function, which can be activated on the touch screen, the self test will also be launched automatically upon start-up, in case of an error, a message will appear in the display. Furthermore, no calibration of the sensor is needed as the sensor uses the CO<sub>2</sub> content in the ambient air as background reference.

### The principle of operation

When the carton has been packed it is led by the conveyer belt directly from the packaging machine into the LeakMatic. When an optical sensor detects that a carton is in the test chamber, the vacuum chamber is lowered, creating a sealed chamber around the carton. Now the automatic test cycle starts by evacuating the chamber to a user defined pressure making the packages ballooning. In case of a leak some of the gas in the package will leak into the test chamber.

During the test, sample gas is continuously passing through the highly sensitive CO<sub>2</sub> sensor. An increase in the CO<sub>2</sub> level in the vacuum chamber indicates a leak in the packages. The leak is defined as the increase of CO<sub>2</sub> in ppm/second.

If no leak is detected the vacuum chamber is raised and the carton is automatically led out to a conveyor belt carrying it on in the process. As the chamber is raised a signal indicates that the LeakMatic is ready for the next test and as the tested carton is being led out a new is led in. In case of a leak, a signal indicates that the carton has to be removed from the packaging line. When being led out of the chamber, this signal can be integrated with various solutions for automatic removal of the leaking carton.

## Diagram of the LeakMatic

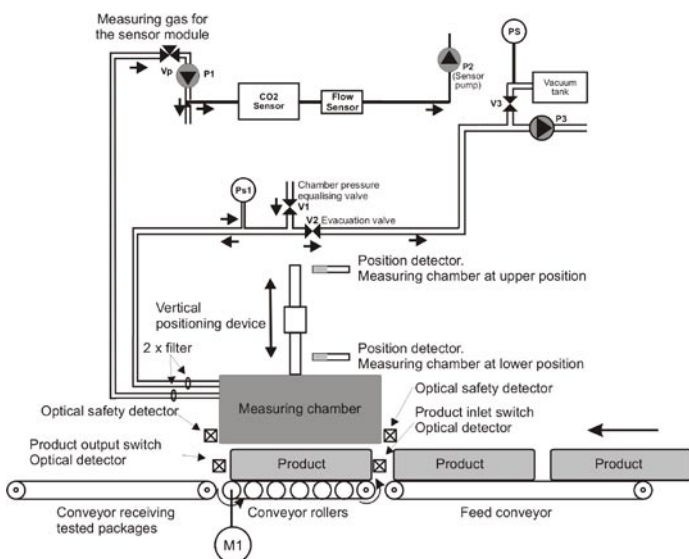

## Set-up programmes and data logging

As the LeakMatic is controlled by a microprocessor it is not just a leak detector but also an advanced test unit with complete documentation of test results. The system features 16 set-up programmes with individual test parameters which can be defined and named/numbered for each package type.

All test results are added to the statistics in the programme used for that particular test. The set-up programmes can be password protected, whereby the users only can change between the existing programmes and only users with password access can alter programmes.

The stored test results and test parameters can be transferred to a computer or to an external printer. The statistical data can also be shown in the display as: Total number of tests, number of items passing the test, number of items failing the test and number of items rejected by the operator.

The statistics are a very efficient tool for documentation of the product quality as no manual recording is needed. With the computer interface it is easy to export or print test statistics with time, date and programme or to transfer the data to a PC.

## LeakStat Software

A software is also available for the LeakMatic. The software allows real time monitoring of the test from an external computer. Furthermore, software stores all test data and easy facilitates comparison of tests data for various time periods or products.



Technical specifications	
Sensor type:	Nasicon. Ceramic, solid-matter CO <sub>2</sub> sensor
Measuring gas:	Clean and dry gases with a minimum of 10% CO <sub>2</sub>
Min. detection level of CO <sub>2</sub> :	10 ppm/sec. above the surrounding atmosphere level.
Sensor reaction time:	Maximum 50 milliseconds
Heating time:	40 minutes from cold condition. The remaining time is displayed.
Test cycle:	4-5 tests per minute
Control panel:	Graphical background exposed display with touch screen and icon based navigation.
Alarms/Signals:	System ready Ready to test product Test OK Leak
Interfaces:	RS 232
Max. standard test item size:	350 mm x 600 mm x 400mm (HxWxD)
Cabinet size:	1825 mm x 880 mm x 1050 mm (HxWxD)
Weight:	Approx. 450 kg
Protection class	IP 53

PBI/DS-Dash-Gastech-LM-UK-1



**TENDRING** *pacific*  
www.tendringpacific.com

Norfolk House, Great Chesterford Court, Great Chesterford, Essex CB10 1PF  
T: (44) 0870 240 1886 F: (44) 0870 240 1887 E: sales@tendringpacific.com



PBI-Dansensor America Inc. . 139 Harristown Road . Glen Rock, NJ 07452 . USA  
Tel.: (+1) 201 251 6490 . Fax: (+1) 201 251 6491  
e-mail: sales@pbi-dansensor.us . Website: www.pbi-dansensor.us

Headquarter: PBI-Dansensor A/S . DK - 4100 Ringsted . Denmark  
Tel.: +45 57 66 00 88 . Fax: +45 57 66 00 99  
e-mail: info@pbi-dansensor.com . Website: www.pbi-dansensor.com